

21K GUYSTRAINS – CLEVIS / CLEVIS

**SPECIFICATIONS**

**FITTINGS:** DUCTILE IRON, 654512

**ROD:** SOLID, ELECTRICAL GLASS ROVING WITH ULTRA-VIOLET INHIBITORS. VEIL COATED.

**HARDWARE:** STEEL, HOT DIP GALVANIZED (CLEVIS PIN) / STAINLESS STEEL (COTTER PIN)

CATALOG NUMBER	LENGTH "A" INCHES	LENGTH "B" INCHES
FCC21-12	12	20
FCC21-18	18	26
FCC21-24	24	32
FCC21-30	30 </td <td>38</td>	38
FCC21-36	36	44
FCC21-42	42	50
FCC21-54	54	62
FCC21-60	60	68
FCC21-78	78	86
FCC21-96	96	104
FCC21-120	120	128
FCC21-144	144	152

RECOMMENDED WORKING LOAD 50% OF RATING LISTED

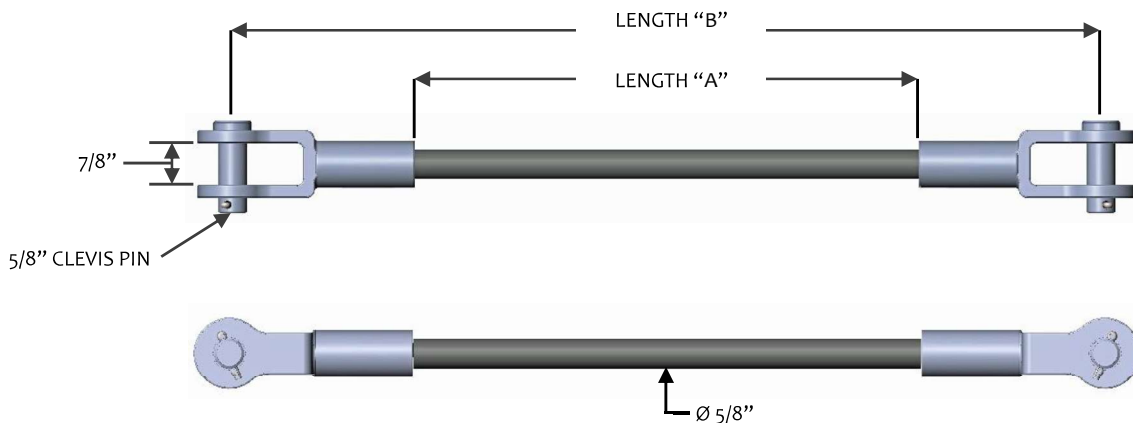

**NOTE:**

FOR OTHER LENGTHS PLEASE CONTACT US.

ADD SUFFIX "R" FOR (1) ROLLER (Example: FCC21-18R).

ADD SUFFIX "R2" FOR (2) ROLLERS (Example: FCC21-24R2).